

**PULL TO  
UP SHIFT**

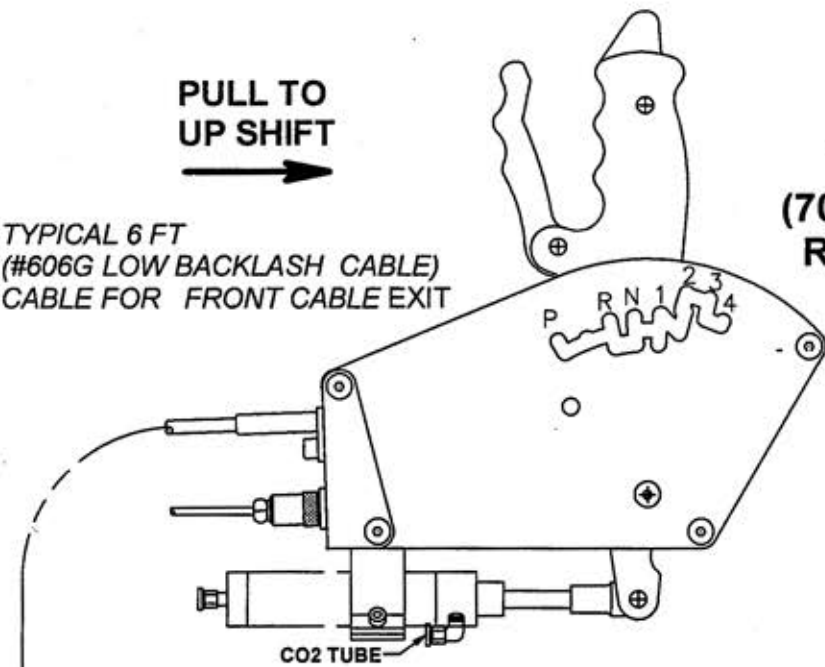

TYPICAL 6 FT  
(#606G LOW BACKLASH CABLE)  
CABLE FOR FRONT CABLE EXIT



#468-FT-R T/H 4 SPEED REVERSE (RED)  
#468-FT-B T/H 4 SPEED REVERSE (BLACK)  
(FRONT CABLE EXIT)

**KWIK-SHIFT I  
POWER SHIFT  
TURBO HYDRO  
(700R4, 4L60 & 4L80)  
REVERSE 4 SPEED  
(P R N 1 2 3 4)  
VALVE BODY**

**PUSH TO  
UP SHIFT**



TYPICAL 5 FT  
(#605G LOW BACKLASH CABLE)  
CABLE FOR REAR CABLE EXIT

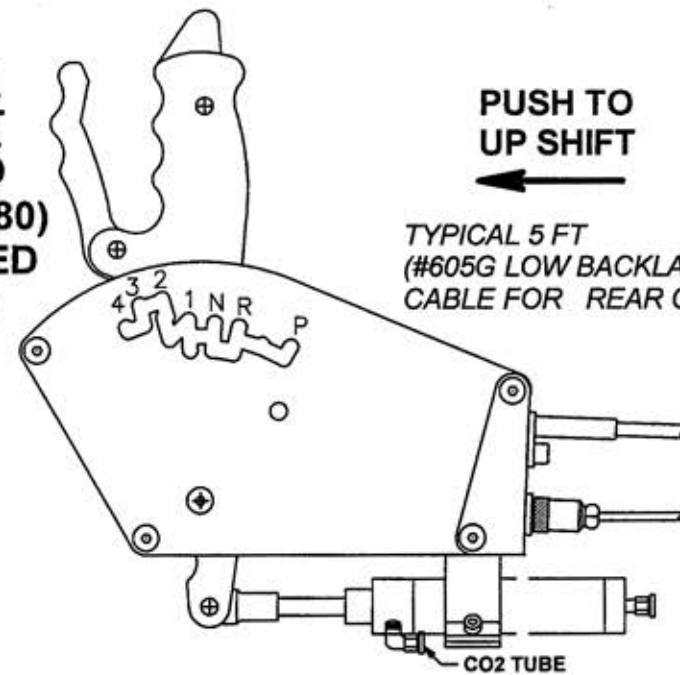

#468-REAR-R T/H 4 SPEED REVERSE (RED)  
#468-REAR-B T/H 4 SPEED (BLACK)  
(REAR CABLE EXIT)

**FRONT OF  
VEHICLE**

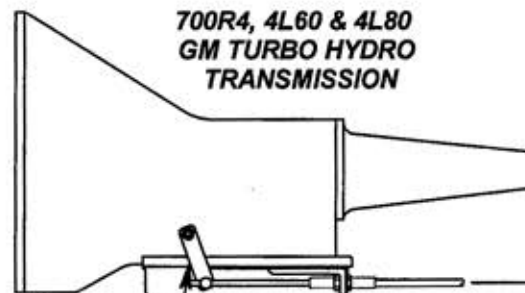

700R4, 4L60 & 4L80  
GM TURBO HYDRO  
TRANSMISSION

TRANSMISSION  
REAR CABLE  
ENTRY

#641 (700R4 & 4L60) LEVER  
#631 (4L80) LEVER

#643 (700R4 & 4L60) CABLE BRACKET  
#632 (4L80) CABLE BRACKET

#640 KIT, LEVER & CABLE BRACKET (700R4 & 4L60)  
#630 KIT, LEVER & CABLE BRACKET (4L80)

NOTE: BRACKET SPACERS FURNISHED ARE NOT REQUIRED  
WHEN USING CAST ALUM. OIL PAN

**PRECISION PERFORMANCE PRODUCTS**  
**KWIKSHIFT I POWERSHIFT**  
**TURBO HYDRO REVERSE 4 SPEED**  
07-31-2016 TH K/S1 Air Rev 4 Speed1.vc6