

**PULL TO
UP SHIFT**
→

KWIK-SHIFT II
MANUAL

**C4 & C6 FORD
REVERSE (P R N 1 2 3)
VALVE BODY**

**PUSH TO
UP SHIFT**
←

#241B-FT C4 & C6 FORD (BLACK)
(FRONT CABLE EXIT PUSH)

#241B-REAR C4 & C6 FORD (BLACK)
(REAR CABLE EXIT, PULL)

OPTIONAL #340 AIR CYLINDER

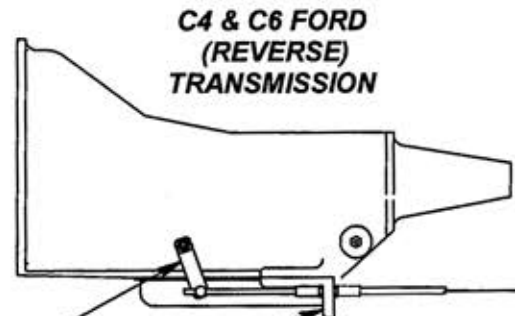

**TRANSMISSION
REAR CABLE ENTRY**

- #636 C4/C6 LEVER ONLY
- #637 C4 CABLE BRACKET
- #638 C6 CABLE BRACKET

- #634 KIT, C4 LEVER & CABLE BRACKET
- #635 KIT, C6 LEVER & CABLE BRACKET

**NOTE: BRACKET SPACERS FURNISHED ARE NOT
REQUIRED WHEN USING CAST ALUM. OIL PAN**

**NOTE: ALL SHIFTERS START IN NEUTRAL AND PARK
POSITIONS**

PRECISION PERFORMANCE PRODUCTS
KWIK-SHIFT II

C4 & C5 FORD REVERSE VALVE BODY
11-12-16 C4 C6 Ford Rev2.vc6