

KWIK-SHIFT II

**CHRYLSEY MANUAL / AIR
TORQUE-FLITE
(#904 , #727 RE48 RE47)
REVERSE (P R N 1 2 3)
VALVE BODY**

TYPICAL 5 FT (#605)
CABLE FOR FRONT
CABLE EXIT

TYPICAL 6 FT (#606)
CABLE FOR REAR
CABLE EXIT

#340 OPTIONAL
AIR CYLINDER

#231B-FT CHRY REVERSE (BLACK)
(FRONT CABLE EXIT)

#231B-FT CHRY REVERSE (BLACK)
(REAR CABLE EXIT)

FRONT OF
VEHICLE
←

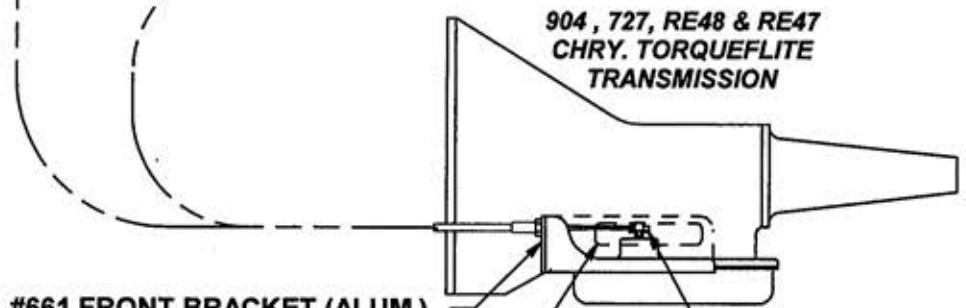

904, 727, RE48 & RE47
CHRY. TORQUEFLITE
TRANSMISSION

#661 FRONT BRACKET (ALUM.)
WITHOUT TRANSMISSION
BLANKET SHIELD

#653 FRONT BRACKET (ALUM.)
WITH TRANSMISSION
BLANKET SHIELD

#656 LEVER

NOTE: BRACKET SPACERS
FURNISHED ARE NOT REQUIRED
WHEN USING CAST ALUM. OIL PAN

KITS, LEVER AND TRANSMISSION BRACKETS
#660 KIT, FRONT ENTRY ALUM. BRACKET & LEVER
(WITHOUT TRANSMISSION BLANKET SHIELD)
#658 KIT, FRONT ENTRY ALUM. BRACKET & LEVER
(WITH TRANSMISSION BLANKET SHIELD)

PRECISION PERFORMANCE PRODUCTS
KWIK SHIFT II
CHRYSLER TORQUEFLITE MANUAL/AIR
REVERSE PATTERN
(FRONT TRANSMISSION ENTRY)
07-31-16 Chry Rev2.VC6