

KWIK-SHIFT II

CHRYSLER MANUAL / AIR TORQUE-FLITE
(#904 , #727 48RE 47RE)
STANDARD (P R N 3 2 1)
VALVE BODY

PULL TO UP SHIFT
 →
 TYPICAL 5 FT (#605)
 CABLE FOR FRONT
 CABLE EXIT

PUSH TO UP SHIFT
 ←
 TYPICAL 6 FT (#606)
 CABLE FOR REAR
 CABLE EXIT

#226B-FT CHRY STANDARD (BLACK)
(FRONT CABLE EXIT)

#226B-REAR CHRY STANDARD (BLACK)
(REAR CABLE EXIT)

FRONT OF VEHICLE
 ←

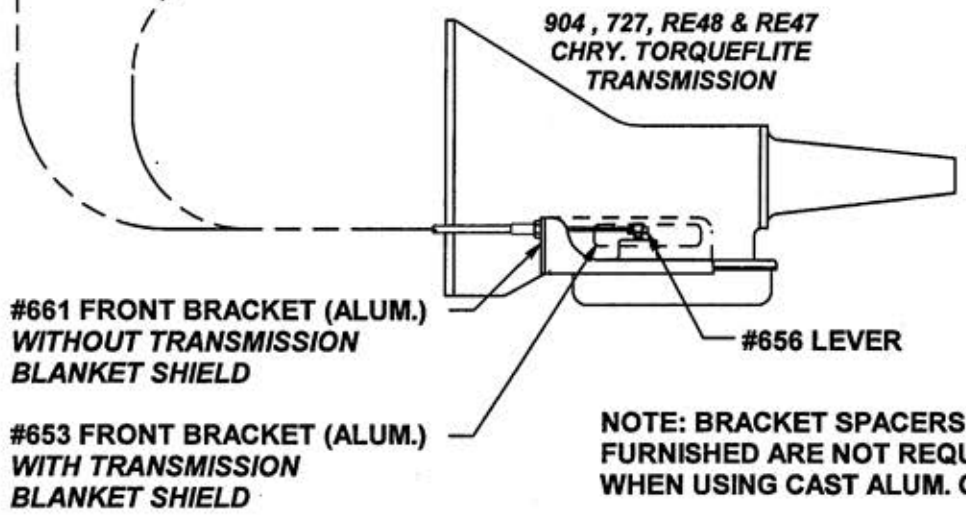

#661 FRONT BRACKET (ALUM.)
WITHOUT TRANSMISSION
BLANKET SHIELD

#653 FRONT BRACKET (ALUM.)
WITH TRANSMISSION
BLANKET SHIELD

#656 LEVER

NOTE: BRACKET SPACERS
FURNISHED ARE NOT REQUIRED
WHEN USING CAST ALUM. OIL PAN

KITS, LEVER AND TRANSMISSION BRACKETS
#660 KIT, FRONT ENTRY ALUM. BRACKET & LEVER
(WITHOUT TRANSMISSION BLANKET SHIELD)

#658 KIT, FRONT ENTRY ALUM. BRACKET & LEVER
(WITH TRANSMISSION BLANKET SHIELD)

PRECISION PERFORMANCE PRODUCTS
KWIK SHIFT II
CHRYSLER TORQUEFLITE MANUAL/AIR
STANDARD PATTERN
(FRONT TRANSMISSION ENTRY)
10-15-16 Chry Std2.VC6